

harman kardon

MODEL D-200

The Recital

COMBINED TUNER, AMPLIFIER AND PREAMPLIFIER

OPERATION AND SERVICE INSTRUCTIONS

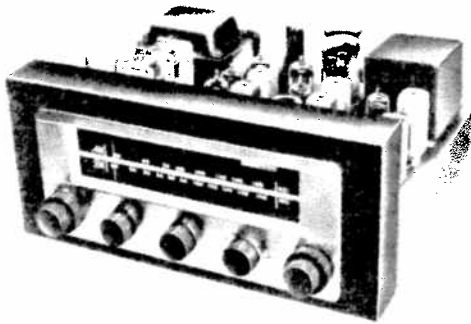

UNPACKING

After unpacking the Recital, inspect it carefully for any signs of damage in transit. Your unit was subjected to many inspections and tests, and then carefully packed. If any damage is visible, notify your dealer immediately. If the unit was shipped to you, notify the transportation company at once.

Check the contents of the package carefully. You should find:

- 1-Recital, Model D-200
- 1-Instruction booklet
- 1-Antenna Wire, hanked
- 1-Warranty card

It is strongly urged that the warranty card be completed and mailed without delay, to protect your rights under warranty. If you should require repair service or information on the use of the Recital, we will be able to identify your unit immediately, and respond quickly.

VENTILATION

All electrical equipment generates heat which must be allowed to escape. Although the Recital is well

ventilated in itself, sufficient space should be allowed around it to permit free air flow. If it is placed in a bookcase, it should be located well toward the front, to provide as much clearance as possible at the rear.

Do not put books or other objects on top of the Recital. Covering the perforated tube grill will reduce the ventilation and result in sharply reduced component and tube life.

SPEAKER CONNECTIONS

Provision has been made to connect to any of today's fine speaker systems. A three-screw terminal strip marked "SPEAKER" is located on the rear of the chassis. The terminals are identified as "G", "8", and "16". The generous use of inverse feedback in the design of the Recital permits the connection of practically any speaker between either the "G" and "8" terminals or the "G" and "16" terminals with negligible difference in results. For optimum results and maximum damping factor, it is suggested that speaker systems with a rated impedance between 4 and 12 ohms be connected between "G" and "8". Speaker systems with a rated impedance between 12 and 24 ohms should be connected between "G" and "16".

HARMAN - KARDON, INC.

520 MAIN STREET, WESTBURY, L. I., N. Y.

ANTENNA CONNECTIONS

AM

The Harman-Kardon ceramic loop stick built into the Recital comprises all the antenna required for the finest in noise-free local AM reception.

In locations more removed from metropolitan areas, an outdoor antenna may be required. This should consist of a single wire, as long as is reasonably practical, located away from large metal objects, power lines, or electrical machinery. Connect one end to the "AM" terminal of the "ANTENNA" terminal strip on the rear of the chassis.

FM

Due to the extremely high FM sensitivity of the Recital, the 48" wire furnished will be sufficient antenna for all but the most difficult locations. One end of the wire should be connected to the "FM" terminal of the "ANTENNA" terminal strip, the other end being left free and extended as may be convenient. In remote locations, a standard roof-top dipole and suitable twin lead wire may be used, connected between the "FM" and "G" terminals.

POWER CONNECTIONS

If your music system is limited to AM and FM radio reception, all that is now necessary for operation is to plug the power cord into any outlet furnishing 117 volts, 60 cycles house current. The exact voltage is relatively unimportant, and may vary between 105 and 125; be sure, however, that you have 60 cycle AC power. For your convenience, the power cord of the Recital has been made extra long. An auxiliary AC receptacle is incorporated on the chassis to furnish power to an associated device, such as record changer, tape recorder, etc.

PHONOGRAPH CONNECTIONS

Any type of record player will operate with the Recital. To derive maximum enjoyment it is suggested that a high quality pickup cartridge and a rumble-free turntable be used. Two classes of pickup cartridges are in general use: Magnetic (GE, Pickering, Clarkstan, Fairchild, and Audak) and Crystal (including the newly developed ceramics). While any type of cartridge may be used with the Recital, it is strongly urged that the magnetic type be selected. It should be plugged into the receptacle marked "PHONO". Connect crystal or ceramic cartridges to the receptacle marked "AUX".

A word of advice: The useful life of a phonograph needle is quite short, ranging from 15 minutes to several hours. In addition to degradation of tone quality as the needle wears, the strong possibility exists that valuable records will be damaged if worn needles are not promptly replaced. The purchase of a diamond, which has very long life, is therefore a worthwhile investment.

The power cord of the turntable may be plugged into the auxiliary outlet on the rear of the Recital chassis. It is sometimes advisable to ground the phonograph

chassis to the receiver, to reduce hum or other unwanted noises. This may be accomplished by the use of any type of wire, one end connected to the "G" terminal of the "ANTENNA" or "SPEAKER" terminal strips, the other end connected to the metal framework of the phonograph.

AUXILIARY INPUTS

An input receptacle marked "AUX" is located on the rear of the Recital chassis. Any auxiliary equipment, such as a tape recorder or television tuner may be connected to this receptacle and can then be played through the fine audio system of the Recital.

TAPE RECORDING

A receptacle marked "DET" is located on the rear of the Recital chassis. This is used to provide output to a tape recorder or other auxiliary equipment. Any program material, whether AM or FM radio, phonograph, etc., appearing at the "SPEAKER" terminals also appears at the "DET" receptacle, but unmodified by the volume and tone controls. This makes it possible to record programs with the proper recording equalization (as determined by your tape recorder).

AUTOMATIC FREQUENCY CONTROL (AFC)

FM Broadcasting, by its very nature, eliminates almost all natural and man-made static. However, the characteristics of FM which makes this possible also make for problems in tuning. The Harman-Kardon Recital incorporates an effective Automatic Frequency Control (AFC) circuit that overcomes these problems and insures proper tuning even if the manual tuning is not accurately done. The following experiment will lead to an understanding of AFC, and the fuller enjoyment of the Recital. First, tune across the FM scale. Note how the stations "pop" into place, one after the other. Now tune to any station, preferably one with a musical program. Press the tuning knob in to defeat the AFC, and tune slowly through the station from left to right. Notice that there are three points where the station sounds clean, interspersed with points of distorted sound. The middle clean-sounding point is the proper tuning position for the best tone quality with minimum noise and interference. With the knob pressed in, tune slightly away from the proper tuning position, until the sound is distorted. Release the tuning knob to reactivate the AFC, and notice how the sound clears up, as if the receiver had been manually retuned.

Actually, the tuning has been readjusted by the operation of the AFC circuit, which automatically retunes the electronic circuits to the center of the station channel.

The AFC circuit of the Harman-Kardon Recital performs the further function of overcoming any tendency of the tuner to drift.

In order to take maximum advantage of the benefits of AFC, it is suggested that fine tuning be done with the knob pressed in, so that the center clean response point can be located. When the knob is released

AFC will improve this careful tuning by a factor of 10 to 1. This procedure is especially recommended in those cases where a weak station is found close to a strong station. Under these conditions, the AFC may tend to reach for the strong station, and completely skip over the weak station. If the weak station is tuned with the AFC defeated, the AFC will lock it in, after the knob is released.

* * * * *

OPERATING INSTRUCTIONS

A full understanding of the relationship among the Recital's operating controls will assure you realization of the rich potential of this excellent instrument.

The FUNCTION switch has six positions: AM, FM, Auxiliary and three phono equalizations. Its primary use is to select the desired type of program. A secondary purpose is to select a specific record equalization characteristic.

RECORD EQUALIZATION

In order to assure good reproduction of the wide range of frequencies in music and to make necessary adjustments for the limitations of the recording technique, record manufacturers have found it necessary to modify the actual frequency response of the music while it is being recorded. Thus, to avoid overcutting and consequent distortion, a measured and deliberate reduction is effected in low frequency response by selecting a "turnover frequency" and by recording attenuated response below that point. To assure optimum signal-to-noise at the high frequency end when the record is played at home, the highs are deliberately exaggerated during the recording process. A measured and deliberate boost is effected above a certain frequency. This combination of deliberate exaggeration at the low and high ends of the frequency response can be expressed in a "recording curve". When the record is played a mirror image of that curve should be available so that the ideal "flat" response may be achieved. Since several different recording curves have been used in the past (differing with respect to the turnover points and the degree of emphasis or de-emphasis) a choice of playback curves is provided in Harman-Kardon instruments.

The three record equalization positions compensate for the characteristics of over 30 recording labels:

LP: Most American long-playing records made before 1954 and some European LP's. Labels include: Columbia, London, Mercury, Oceanic, Remington, Tempo, Urania, Vanguard-Bach Guild, Vox, Westminster, RCA Victor (older), Atlantic, Decca, Polyphonic, Cetra-Soria, Esoteric, Haydn Society, MGM, Angel.

RIAA: Most American records made after 1954, all records cut to standards of Audio Engineering Society, NAB, new RCA Victor Ortho, and newly standardized RIAA. Labels include RCA Victor (newer), Extended Play 45, Blue Note Jazz, Canyon, Capitol, Good Time Jazz, Mercury, some London, Bartok, Caedman, Capitol-Cetra, Philharmonic, EMS.

EUR: Most European Long-playing, some American LP's and most 78 RPM discs.

The LOUDNESS control is used to adjust the volume of any program. Its effect is selectively varied by the

DYNAMIC CONTOUR Control. One of the limitations of human hearing is its tendency to lose sensitivity to the very low and very high pitched sounds, as the sound level is reduced. It is this characteristic (known as the Fletcher-Munson effect) which causes one to play music programs at high level in order to experience the fullness of tone available from fine modern recordings and identified with "live" listening. The Harman-Kardon Dynamic Loudness Contour Control compensates for the Fletcher-Munson effect, eliminating high reproduction level as a requisite for full enjoyment of reproduced music. Six positions of compensation are provided, to allow the selection of the one most suited to your hearing.

Each position causes the loudness (Volume) control to perform with a different degree of compensation, the amount increasing with each clockwise setting. Position 1 is uncompensated. Position 2 and 3 provide somewhat less compensation than that required to match the Fletcher-Munson loudness contour curves. Position 4 matches the Fletcher-Munson curves. Position 5 and 6 provide greater amounts of compensation than the curves suggest. Since hearing characteristics vary from person to person (some require more and others less compensation), the great flexibility provided in these controls can be appreciated.

In operation, the proper choice of contour is easily made, by switching through the several loudness contour positions and selecting the one which sounds best to you.

Separate BASS and TREBLE controls are incorporated in the Recital, to provide the full range of adjustment required for satisfactory high fidelity performance.

The TUNING and AFC DEFEAT control is used to tune in the desired broadcast, and also serves to cut out the automatic frequency control at will. Notice the smooth counterweighted feel, found elsewhere only in the most expensive professional equipment.

* * * * *

ORGANIZING THE VARIOUS CONTROLS

In general, every control on a well designed, honestly considered high fidelity instrument has a specific useful function, related to each of the other controls. Although this cannot be a full treatise on the subject, an explanatory note on the relationship of the various front panel controls will doubtless prove useful in organizing and clarifying them for the user.

Beginning with the function selector, choose the type of program material you plan to listen to (tuner, phono, etc.). Choose the correct record equalization

setting for the particular record you are to play. With Loudness Contour Selector in the uncompensated position, turn the loudness (volume) control to as high a level as you can briefly allow. (This to permit you to make the remaining adjustments while you are listening at your own maximum efficiency). Now adjust the Bass and Treble Tone Controls to correct for the electro-mechanical characteristics of the loudspeaker you are using and for the acoustic characteristics of the room in which you are listening. These adjustments are wisely pragmatic.

Modify each until settings are chosen which in your total system create the proper sense of aural balance and evenness. Now reduce the loudness (volume) control setting to a level somewhat lower than normal listening level in your room. You will note that the full bodied - lifelike quality you experienced at high listening level has disappeared (this because of the Fletcher-Munson effect described in the paragraph on the H, K Dynamic Loudness Contour). With all other controls unchanged, select the best contour setting for you. Do this by switching quickly from the uncompensated position to the most compensated and then backing down one position at a time until you find the one which most nearly duplicates the full-bodied sound you enjoyed at high level. Now turn the loudness control up to the level at which you wish to listen - (perhaps the maximum level you can permit in your home) - and listen. You'll find that there is automatic compensation of contour wherever you set the loudness control thereafter. In fact, under normal circumstances, you should not find it necessary to readjust the tone controls or the

contour selector once having chosen the correct settings for you, your room and your system.

HUM PROBLEMS

In some installations where a record-player, tape recorder, or other auxiliary AC operated equipment is used, hum may be encountered due to voltage differences between the various units. This may be eliminated by reversing one or all of the AC power plugs. Simply reverse one at a time until improvement is experienced.

An additional refinement incorporated in the Recital is the special hum balance control located on the top of the chassis near the front panel. This is a screwdriver control which requires initial adjustment whenever new tubes are used in the amplifier section.

To set this control properly, place the function selector on RIAA, advance the volume control to 3/4 of maximum, and vary the balance control for minimum hum.

MAINTENANCE AND REPAIR

Due to the conservative design and high quality components of the Recital, no routine maintenance other than yearly tube-checking is required. Should trouble develop, however, only the most qualified service man should be employed, as special equipment and training is required to properly align a high-fidelity FM receiver.

SPECIFICATIONS

1. RF SECTION:

Circuits: FM: Armstrong circuit with Limiter & Foster-Seeley Discriminator. Automatic Frequency Control—Low Noise Front End consisting of Triode Grounded Amplifier and Triode Mixer. AM: Superheterodyne with A.V.C. and Ferrite Antenna.

Sensitivity: FM—5 microvolts for 30 db quieting; 3 microvolts for 20 db quieting.
—Loop sensitivity 80 microvolts; meter: Terminal sensitivity 20 microvolts

Selectivity: FM—200 KC bandwidth—6 db down
AM—8 KC bandwidth—6 db down

FM discriminator—peak to peak separation 375 KC
Frequency Range: FM: 88-108 MC AM: 530-1650 KC
FM Drift: ± 5 KC max.
Image Rejection: FM: 30 db AM: 30 db
Antenna Input: FM: 300 ohms
AM: Built-in low noise ferrite loopstick plus high impedance terminal for external antenna.

Distortion: Less than 1% harmonic on FM
Less than 1% harmonic for up to 80% mod. on AM
Frequency Response: FM: ± 1/2 db 20 to 20,000 c.p.s. including standard 75 microsecond deemphasis.
AM: 3 db 20 to 5,000 c.p.s.
Hum Level: 60 db below 100% modulation.

2. AUDIO SECTION:

Circuits: Ultra-Linear output circuit employs 2 6L6GB
Power Output: 12 watt at 1% 1M (40 & 7000 cycles)
Peak Power: 20 watts
Frequency Response:
± 1/2 db 10-40,000 c.p.s. ± 1/2 db 40-15,000 at 12 watts.
Damping Factor: 10
Output Impedance: 8 and 16 ohms
Hum: Min. volume hum: 80 db below 12 watts
Aux. and tuner hum: 70 db below 12 watts
Phono hum (in RIAA position): 60 db below 12 watts
Tone Control Range: ± 16 db at 50 and 10,000 c.p.s.
Input Levels: Aux: 0.3 volts, Phono: 6 millivolt
Dynamic Loudness Contour: 6 Positions:
Position 1. Uncompensated.
Position 2. Approximately 10 db less than Fletcher-Munson
Position 3. Approximately 5 db less than Fletcher-Munson
Position 4. Fletcher-Munson compensation
Position 5. Approximately 5 db more than Fletcher-Munson
Position 6. Approximately 10 db more than Fletcher-Munson

3. OVER-ALL SPECIFICATIONS:

Controls: (6 total) Tuning, Function (6 positions: AM, FM, Aux, LP, RIAA, R), Treble, Bass, Loudness and Power (concentric with contour), Contour.

Accessories: 1 AC receptacle on chassis rear, controlled by power switch.
Tube Complement: (Total: 13) 3-12AT7, 1-6BE6, 1-6BA6, 2-6AU6, 1-6AL5, 1-12AU7, 1-12AX7, 2-6L6GB, 1-5Y3GT, 1-selenium rectifier.
Dimensions: 11-15/16" wide x 5-7/16" high x 11-7/16" deep (including ferrite loopstick— not including knobs).
Installation Space Required: 12 1/4" wide, 5 3/4" high, 11 3/4" deep.
Power Consumption: 100 watts.
Shipping Weight: 24 lbs.
Finish: Chassis, escutcheon and DC-2 cage: brushed copper—Display panel for escutcheon and knobs: matte black—Edge lighted dial glass: yellow and white.
Notes: Vertical mounting of Recital permissible without special precaution.
Hardware and Accessory Material Furnished: Mounting wood screws, Template, Instruction booklet, FM antenna wire.
Functional Features:
(a) Counterweighted Tuning Control.
(b) AFC Defeat achieved by depressing tuning knob for center-channel tuning.
(c) Tape Output Receptacle furnished on chassis rear prior to tone controls.

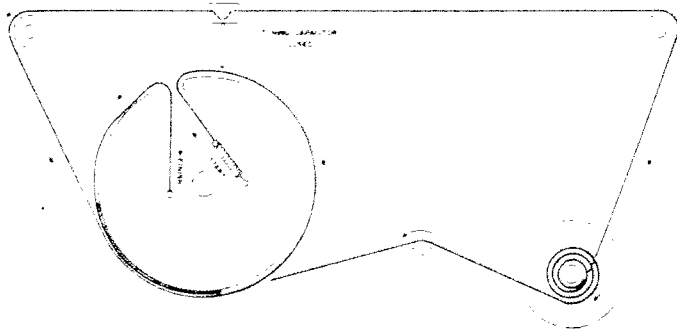

DIAL STRING DIAGRAM FOR MODEL D200
FRONT VIEW

WARRANTY

We warrant each Recital, Model D200 to be free from defects in material and workmanship under normal use and service, and in accordance with the conditions herein below set forth, for a period of 90 days from date of delivery to the original purchaser, and agree to replace or repair any part or parts returned to us within said 90 days, with transportation prepaid, and which our examination shall disclose to our satisfaction to have been thus defective. This warranty does not include free labor, nor is it applicable to any instrument which shall have been repaired or altered in any way so as in our judgment to affect its stability or reliability nor which has been subject to neglect, misuse, abuse, negligence or accident nor which has had the serial number altered, effaced, or removed. Neither shall this warranty apply to any instrument which has been connected otherwise than in accordance with the instructions furnished by us.

This warranty is expressly in lieu of all other warranties, express or implied, and of all other obligations or liabilities on our part, and we neither assume nor authorize any representative or other person to assume for us any other liability in connection with the sale of the Model D200 Recital.

LIST OF REPLACEABLE PARTS

| Description | Part No. | List Price |
|---|------------|------------|
| Power Transformer | FT 421060B | \$27.50 |
| Output Transformer | FT 421061E | 19.50 |
| FM IF Transformer | GT 24605 | 2.70 |
| FM IF Transformer | GT 24606 | 2.70 |
| Discr. Transformer | GT 481423 | 3.15 |
| AM IF Transformer | GT 24610 | 2.10 |
| Ktran clip | Z 24614 | .05 |
| Gang Condenser | JV 471083C | 6.95 |
| FM RF Trimmer | JV 20688 | .30 |
| Electrolytic Cap. 20/400, 20/350, 50/25 | JE 251471 | 5.50 |
| Electrolytic Cap. 40, 40, 40/150 | JE 20635 | 2.75 |
| Electrolytic Cap. 40/400 | JE 251472 | 2.00 |
| Selenium Rectifier | Z 20690 | 2.95 |
| Broadcast Osc. Coil | GL 24601 | .85 |
| Hum Balance Control | RV 421115 | 2.70 |
| Broadcast Antenna | GL 421119C | 2.95 |
| Loudness Control | RV 24721D | 4.55 |
| Tone Control | RV 33897 | 1.25 |
| Dial Glass | P 421064A | 1.75 |
| Dial Glass Retaining Clip | Z 35944 | .05 |
| Pointer | Z 24773 | .30 |
| Function Switch | ER 421069A | 2.10 |
| Display Panel | P 421065C | 3.25 |
| Escutcheon | P 421066B | 6.75 |
| Knob, Outer Coaxial | P 24779 | .12 |
| Knob, Control | P 24780 | .12 |
| Knob, Tuning | P 24781 | .15 |
| Knob, Inner Coaxial | P 24782 | .12 |
| Instruction Booklet | L 421512A | .75 |
| Mounting Template | Z 421091A | .15 |

ALIGNMENT PROCEDURE

| Func. Switch Setting | Signal Freq. | Generator Mod. | Signal Input Point | Output Indicator | Connect To: | Dial Setting | Adjust | Output Indication |
|----------------------|--------------|--------------------|--------------------|------------------|-------------------------------|--------------|----------------------------|----------------------------------|
| AM | 455KC | 30%AM | 6BE6 Pin 7 | AC-VTVM or scope | Output Terminal | | 2 AM IF Transformers | Max. Output |
| AM | 1500KC | 30%AM | AM Ant Terminals | " | " | 1500KC | OSC and Antenna Trimmers | " |
| AM | 600KC | 30%AM | " | " | " | 600KC | OSC coil | Rock Gang for Max. Output |
| FM | 10.7MC | 300KC FM 60 cycles | 12AT7 MIXER Pin 2 | " | "A" on Schematic through 180K | | 3 FM IF Trans. | Max. gain and symmetry |
| FM | 10.7MC | " | " | " | "B" | | Discriminator Transformer | 3 Pattern of Max. gain and symm. |
| FM | 105MC | " | FM Ant. Terminals | " | "A" | 105MC | 106 MC Osc. & Ant. Trimmer | Max. Output |
| FM | 90MC | " | " | " | "A" | 90MC | " | " |

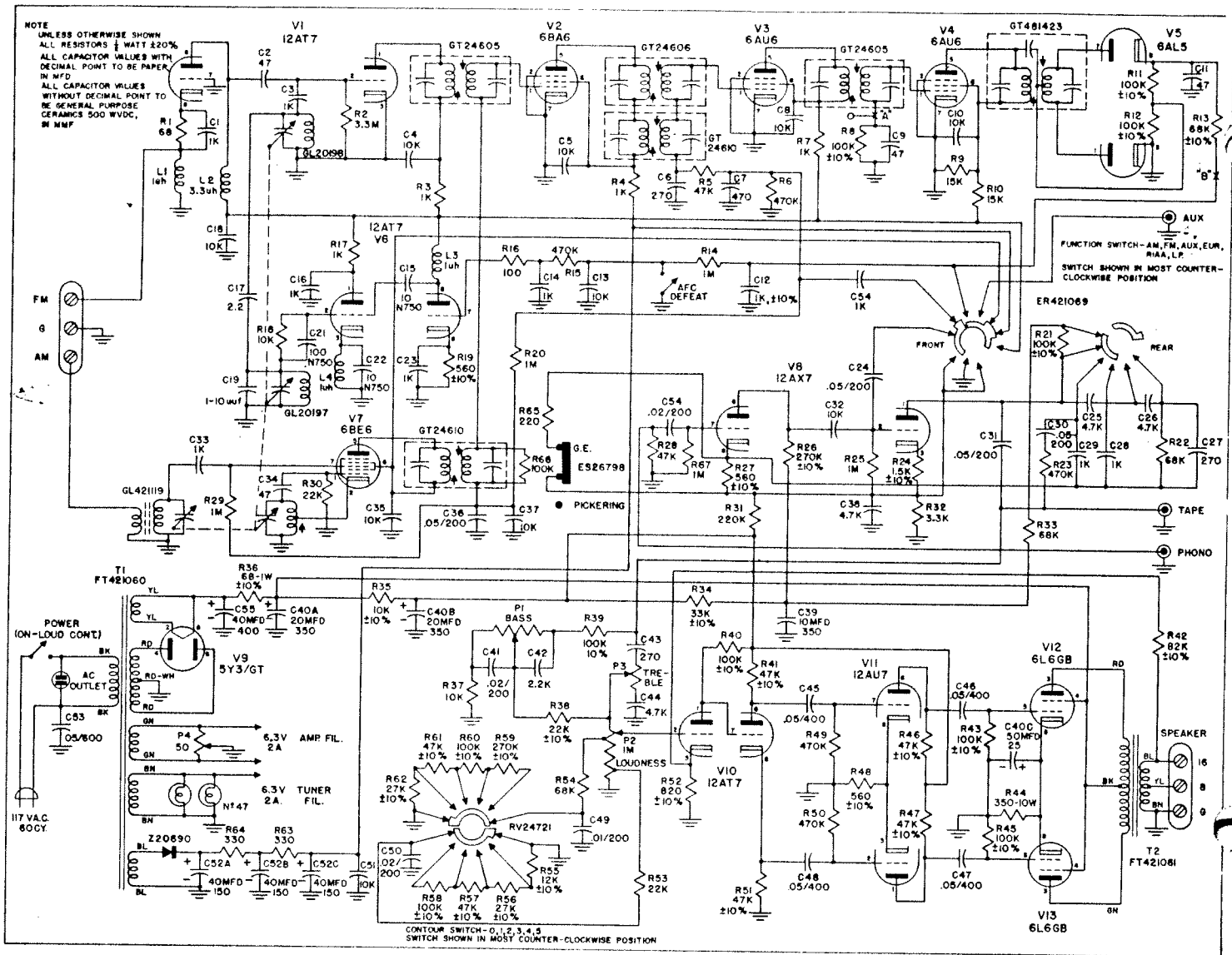

S421220E

MODEL D-200

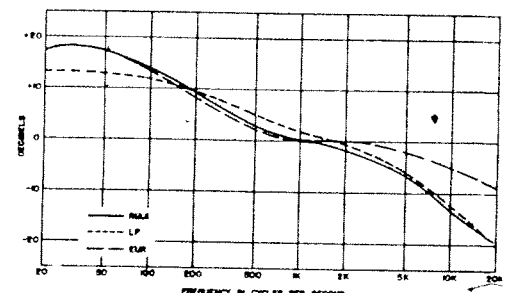
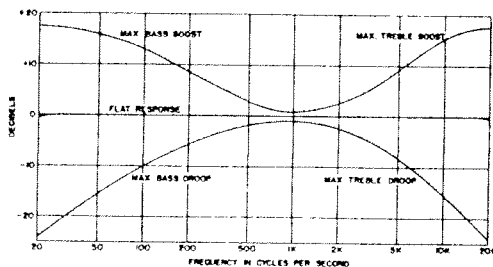
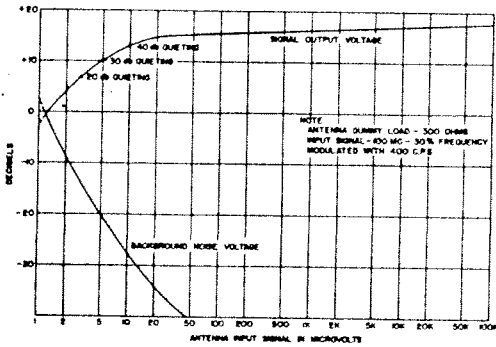

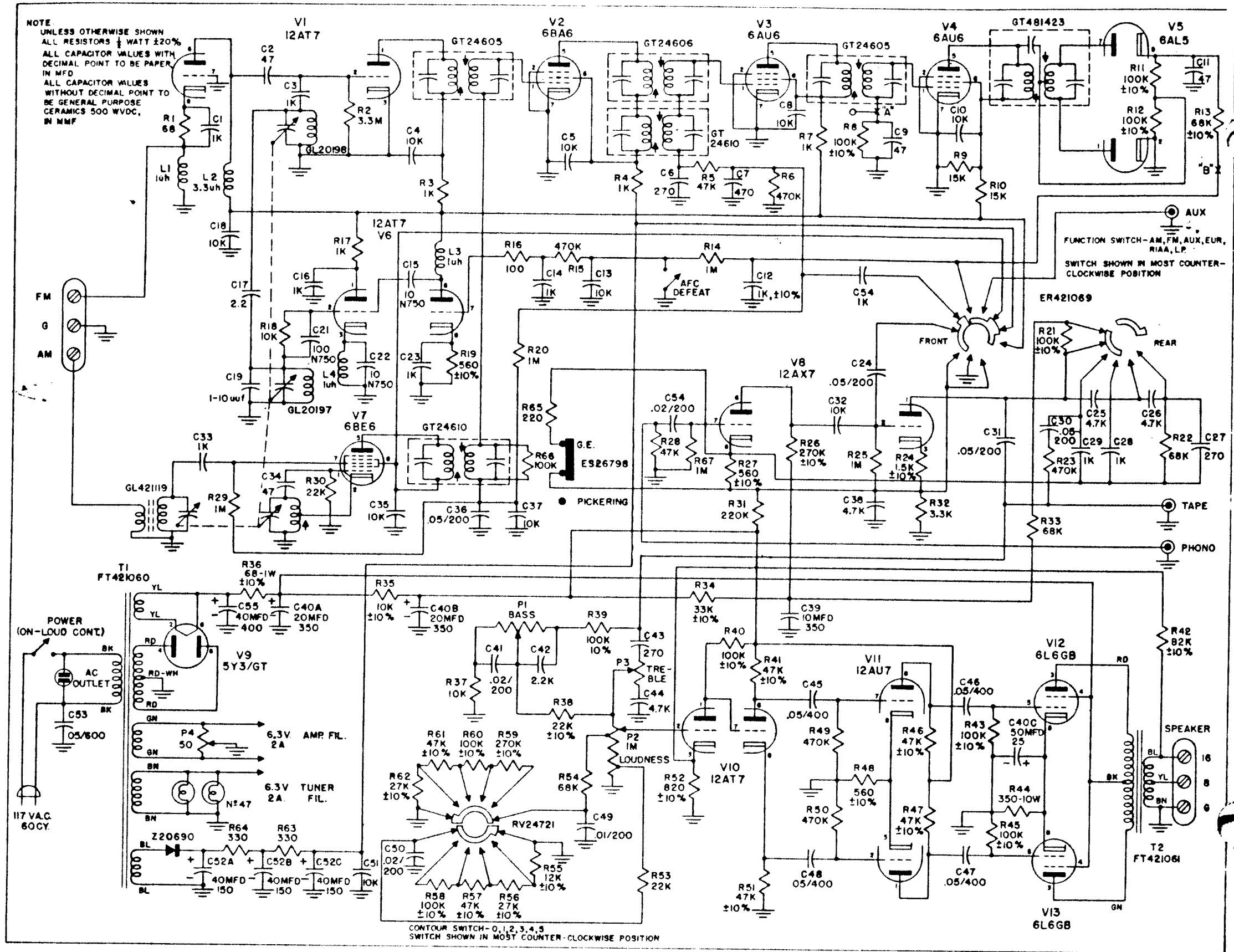

S421220E

MODEL D-200